

CAPACITY	SYMBOL/ SERIAL NO.	CIRCUIT DIAGRAM
AC100-240V, 50/60Hz		
5W		

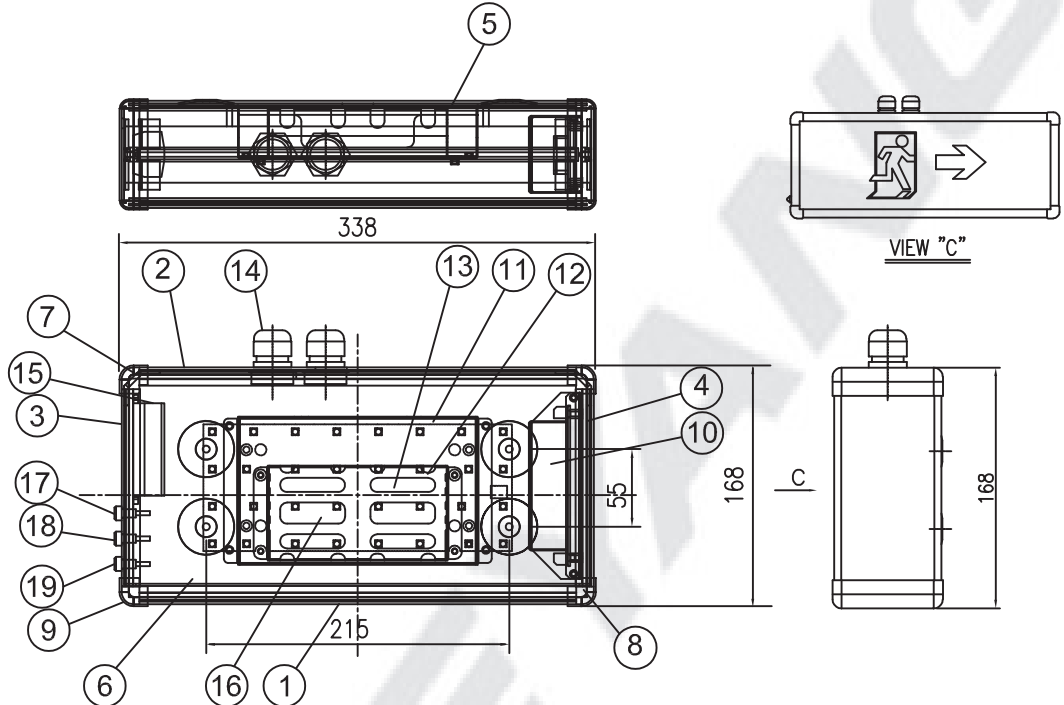

POWER STATUS	BATTERY STATUS	INDICATION LAMP COLOR STATUS	
		GREEN LED STATUS	RED LED STATUS
NORMAL POWER STATE	FULL CHARGING	ON	OFF
NORMAL POWER STATE	CHARGING	ON	OFF
EMERGENCY POWER STATE	DISCHARGING	OFF	OFF
EMERGENCY POWER STATE	FULL DISCHARGING	OFF	ON

- \* RED LED LIGHTS IN THE FOLLOWING SITUATIONS.
- 1. BATTERY IS DISCONNECTED.
- 2. SOMETHING UNEXPECTED OCCURRED IN THE BATTERY.
- \* BATTERY BACK-UP CAN CONFIRM BY PRESSING THE SWITCH DURING NORMAL POWER OPERATION.
- \* CHARGING TIME : 32 hours, DISCHARGING TIME 3 hours

NO	NAME OF PARTS	MATERIAL	Q'TY	REMARKS	NO	NAME OF PARTS	MATERIAL	Q'TY	REMARKS
19	INDICATION LAMP	-	1	RED	10	LED driver CASE	STEEL	1	
18	INDICATION LAMP	-	1	GREEN	9	SIDE COVER	POLYCAR-BONATE	4	
17	NORMAL CLOSE SWITCH	-	1		8	LOWER BRACKET	ALUMINIUM	2	
16	LED module	-	1		7	UPPER BRACKET	ALUMINIUM	2	
15	TERMINAL BLOCK	-	1	CLAMPING 5P	6	SIGN COVER	ACRYL	1	
14	CABLE GLAND(PG16)	-	2	∅12~∅16	5	REAR COVER	STEEL	1	
13	BATTERY	Ni-Cd	1		4	RIGHT BODY	ALUMINIUM	1	
12	BATTERY CASE	STEEL	1		3	LEFT BODY	ALUMINIUM	1	
11	LED module BRACKET	STEEL	1		2	UPPER BODY	ALUMINIUM	1	
					1	LOWER BODY	ALUMINIUM	1	

APPROVED	B. K. KIM	UNIT	MM
CHECKED		SCALE	N/S
DRAWING	B. I. KIM	COLOR	N-9.3
DATE	2018.11.09	IP	44

TITLE;			
LED EXIT LIGHT			
(SURFACE, BATTERY BACKUP TYPE)			
FOR MARINE USE			

	MODEL NO.	LEXIT105SS-0550AB-MR	WEIGHT	3.5 Kg
	DWG NO.	L05110034	SHEET NO.	19

NO	CONTENT	DATE	REVISER	APPROVAL
△				
△				
△				

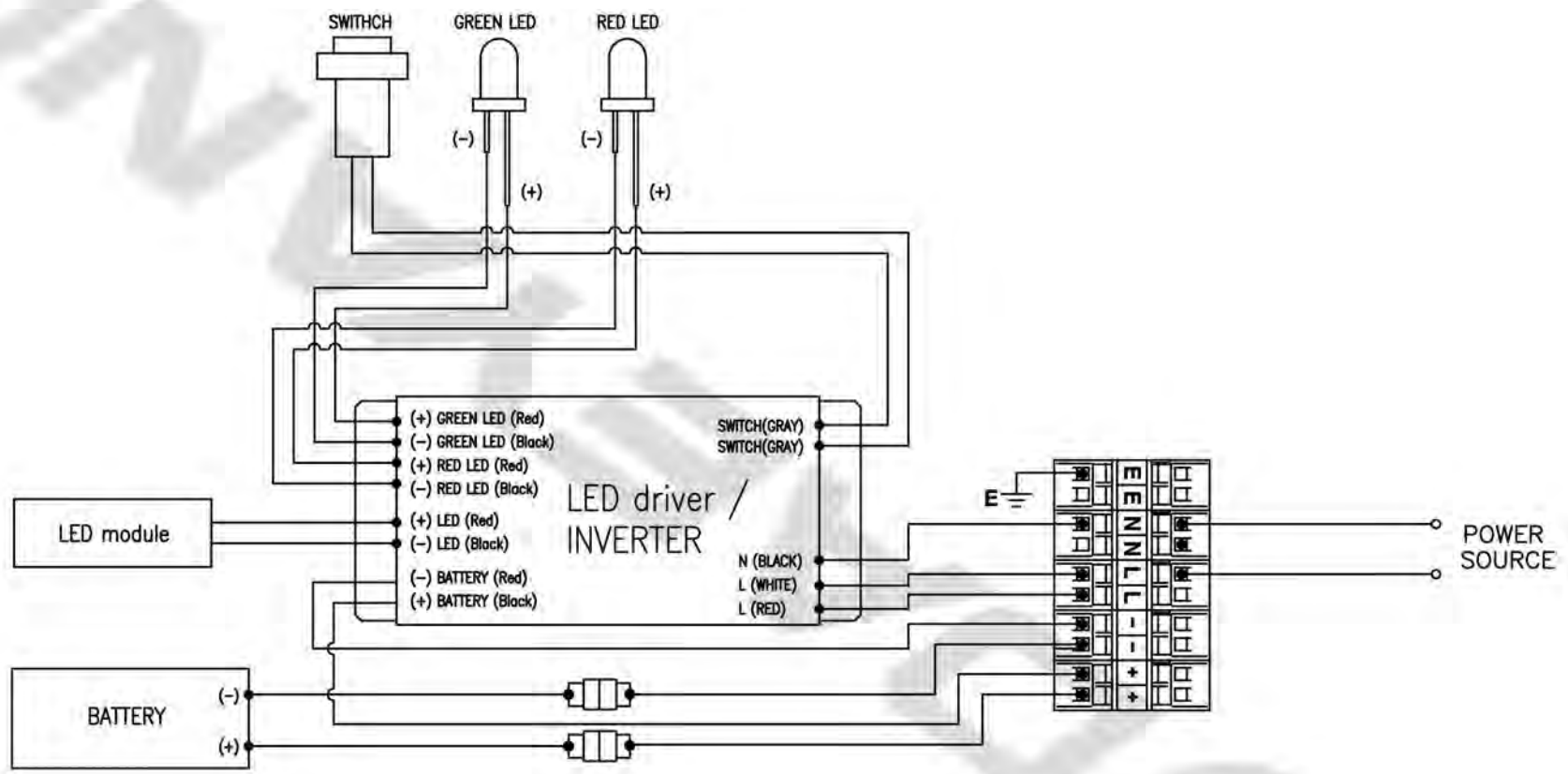

TITLE: LEXIT105SS-0550AB-EMD		SCALE	N/S	UNIT	MM	NO.	REVISED
CIRCUIT DIAGRAM		PROJECT METHOD	WEIGHT	KG		△	
		APPROVED	B. K. KIM			MATERIAL	ASS'Y
		CHECKED				DWG NO.	
		DRAWN	B. I. KIM			SHEET NO.	19-A
		DATE	2018.11.09				